

Collegiate Design Series

# SAE Aero Design<sup>®</sup>

---

# Welcome Packet West 2024



Collegiate Design Series

# SAE Aero Design®

---

## Welcome to California!

### Aero Design East 2024 Staff and Rules Committee:

**Ed Rooney: West, Contest Director**

**Emma Chao: West Deputy Director**

**Lonnie Dong: Rules Committee Chairman**

**David Moroniti: Scoring Lead**

**Glenn Cashion: Head Judge & Power Limiter Tech Support**

**Ryan Reynolds: Weigh Station Lead**

**Josh Childs: Chief Inspector**

**Tom Blakeney: Asst. Chief Inspector**



Collegiate Design Series

# SAE Aero Design®

---

## Welcome to California!

### SAE International Staff:

**Brett Foley** - Aero Design Program Lead

**Gaage Marry** – Support Staff

**Scott Schultz** - Support Staff



# SAE Aero Design<sup>®</sup>

---

- Weekend Overview

- Friday

- Tech Inspection, Field Open for Flying, Safety Presentation (Meals Provided), Presentation by Skunk Works Chief Engineer on Flight Controls

- Saturday

- Competition Flying

- Sunday

- Competition Flying and Awards Ceremony

# SAE Aero Design<sup>®</sup>

---

- Weekend Overview Timelines

Day	Date	Gates Opens	Meetings ?	Field Open for Flying	Field Closes	Gates Closes	Lunch Served
Friday	04/12/20 24	0700	All at 1700	0900	~1700	1730	No
Saturday	04/13/20 24	0700	Pilots at 0730	0800	1730	1800	Yes
Sunday	04/14/20 24	0700	Pilots at 0730	0800	1300	1500	Yes



# SAE Aero Design®

---

## Tent and Field Rules

- One table per team
- Four chairs per team
- Teams Select their table from one of two areas on the field
- No electricity in tents: use power/charging area for power needs.
- Motor testing in designated area.
- Please remember: only student teams members can work on aircraft. Please do not allow ineligible people to work on your aircraft.
- SAE International and all teams are guests of the air field! Keep your areas CLEAN!



# SAE Aero Design<sup>®</sup>

---

The following entry and exit rules below are site requirements:

1. The air field **cannot** be entered before 7AM. Please do not ask to get in before 7AM.
2. Teams that do not have their own vehicles must pre-arrange for their own reliable and scheduled transportation. This transportation must be at the field to pick teams up no later than 5:30PM Saturday and 3PM Sunday. You must have transportation with enough seats for all team members.
3. All teams must be out of the park by 5:30PM.
4. Our last volunteer workers cannot leave the field until all teams have left.
5. Please be polite and cooperative at all times with all airport officials and with the event officials and volunteers. See rules numbers 1.17.1 and 1.17.2.
6. There will be NO flying at the field outside scheduled hours, please, do not ask.



# SAE Aero Design®

---

## California Wildlife WARNING / Location Awareness

- Do not attempt to recover an aircraft without a volunteer and approval to do so from the Flight Line Boss
- Although we are in a city, the airfield is located within a major park/wetlands
  - Be mindful of wildlife when walking off paths (snakes, etc.)
- Do not leave anything of value overnight at the field
  - Although we have security, you are responsible for your own equipment and material at the end of each day.



# SAE Aero Design<sup>®</sup>

---

## Nearby/Onsite Hobby Shops:

- **E Hobby House (On Site & Nearby)**
  - 17721 Vanowen St, Reseda, CA 91335
- **Other Vendors in work!**



# SAE Aero Design®



### Van Nuys RC field

4.9 ★★★★★ 37 reviews  
Recreation

- Directions
- Save
- Nearby
- Send to your phone
- Share

- Lake Balboa, CA 91406
- Located in: Sepulveda Basin Recreation Area
- Open now: 5:30AM–10:30PM
- valleyflyers.club
- (818) 652-9366
- 5GF8+QX Lake Balboa, Los Angeles, CA
- Claim this business

Suggest an edit

Popular times Sundays

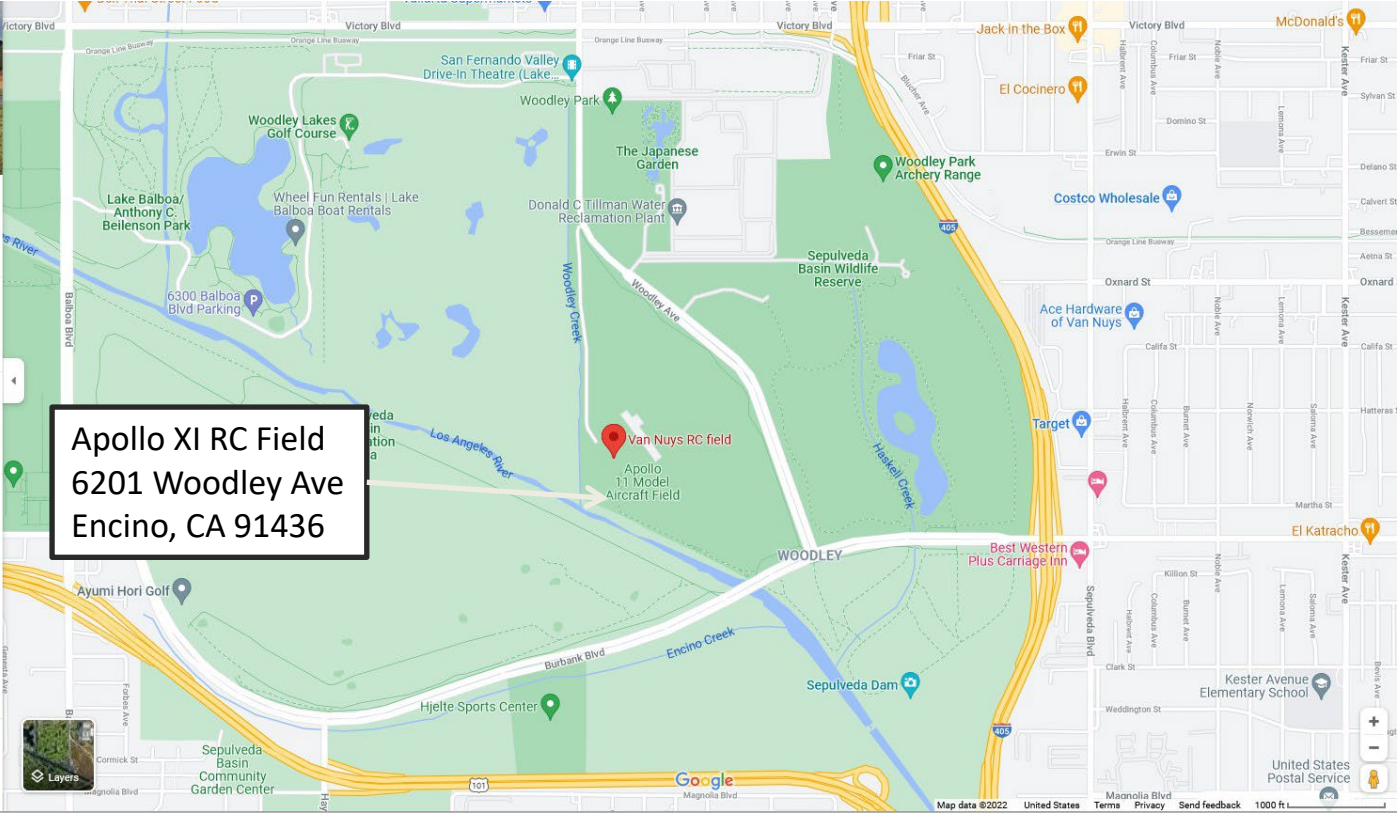

Apollo XI RC Field  
6201 Woodley Ave  
Encino, CA 91436



# Field Location



# Infield Setup

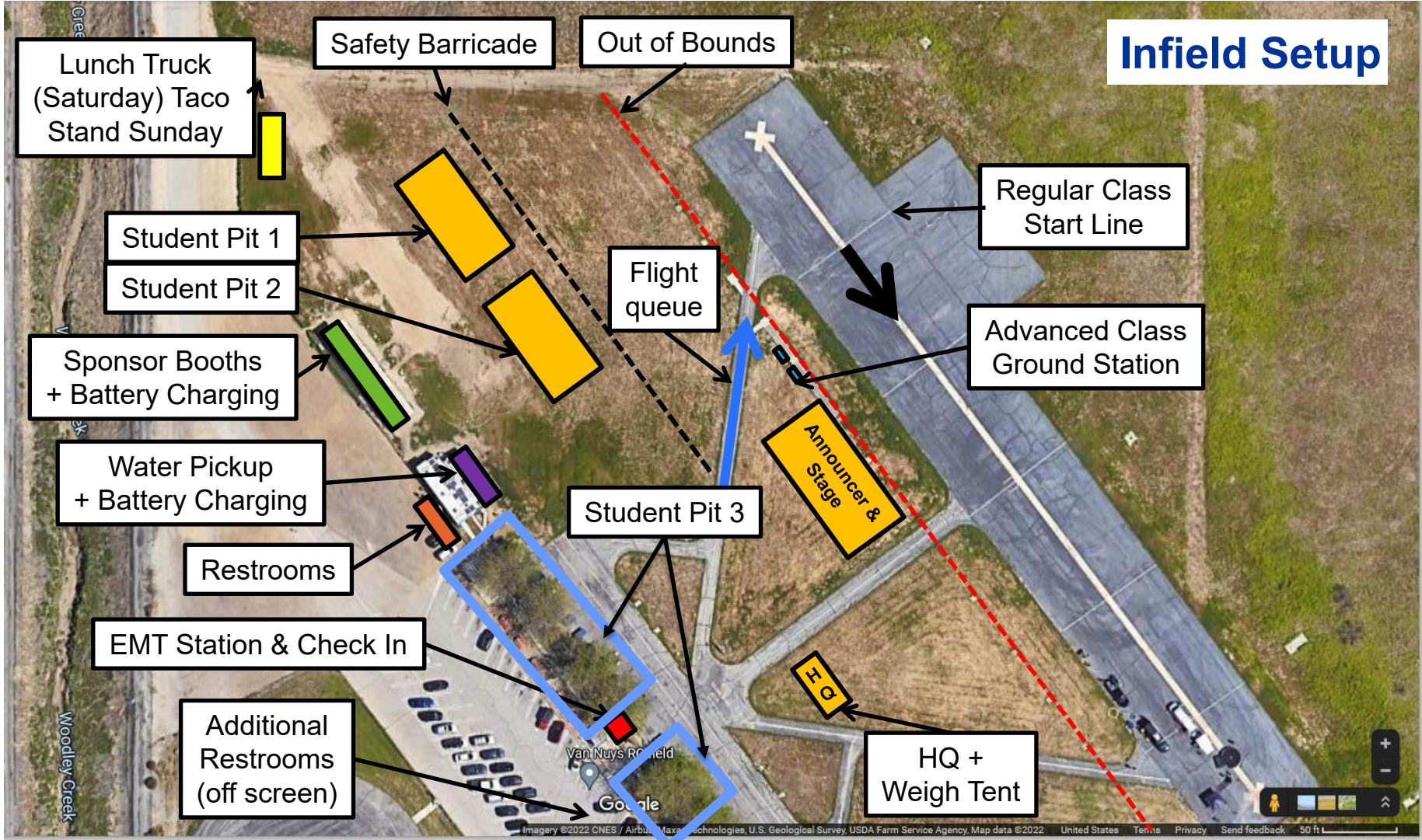

# SAE Aero Design<sup>®</sup>

---

## INSPECTION SUMMARY

- Schedule to be released No later than next week , show up early
- Teams must certify planes meet 100% of the rules, in saestars.com, before inspection.
- If you have questions use the forum or ask red hats at inspection before your inspection.
- Once inspections start any non-compliance will result in loss of points.
- Primary aircraft are given priority at inspection
- Inspection will consist of two components
  - Rules Compliance and Local Field compliance/ Airworthiness

# SAE Aero Design®

---

## FLIGHT OPS SUMMARY

- Teams must have a Flight Card to enter the Flight Queue
- Flight Cards are Available at the SAE HQ Desk
- Pilot's meeting at 7:30AM (SATURDAY/SUNDAY)
- Flying starts at 8:00AM (ALL DAYS)
  - All videos required to have been submitted prior to first flight Saturday
- Must clear field and leave site by 5:30PM (Gates Locked)
  - Vehicle pickup arrangements must be called by 5:00PM (Uber, Taxi, etc...)

# SAE Aero Design<sup>®</sup>

## MICRO FLIGHT OPS SUMMARY

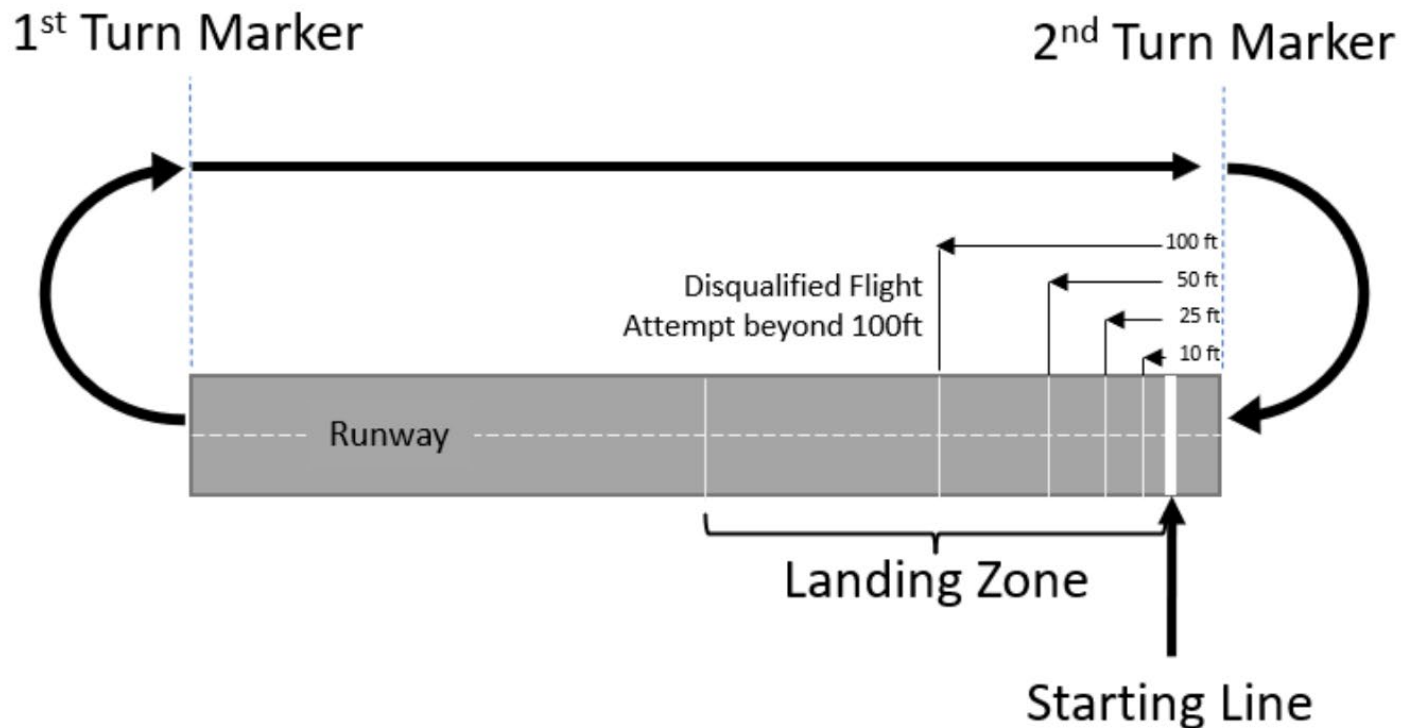

# SAE Aero Design<sup>®</sup>

## MICRO FLIGHT OPS SUMMARY

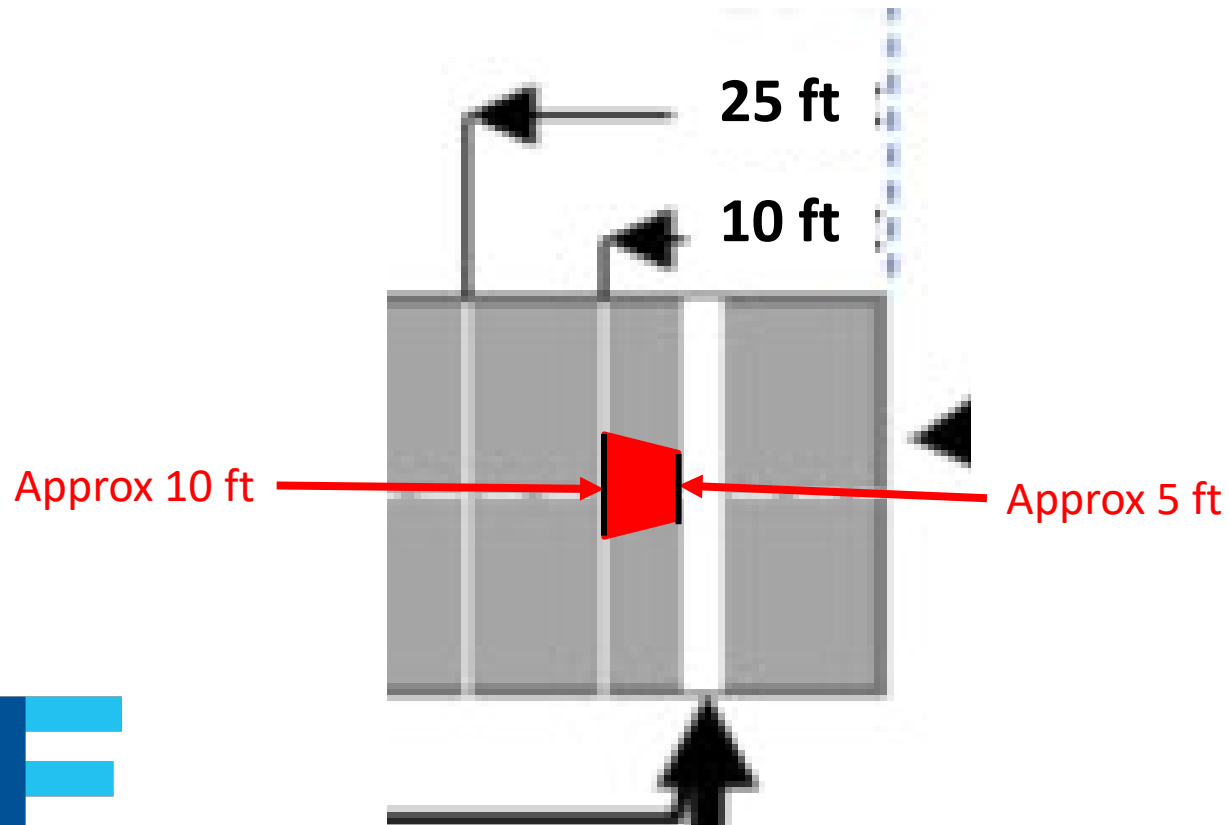

# SAE Aero Design<sup>®</sup>

## REGULAR FLIGHT OPS SUMMARY

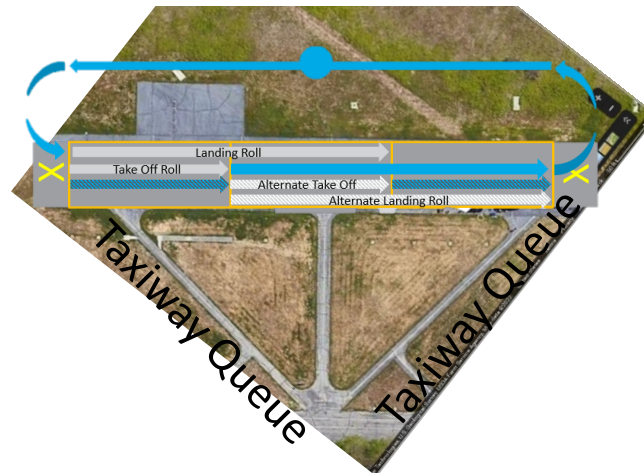

- 3-Team Members at Flight-Line.
- Take-Off Time: 120s
- Land in same direction as take-off on Pavement.
- 100 ft take-off zone.
  - One take-off allowed.
  - Aircraft leaving pavement is a take-off.
  - One attempt per flight card.



# SAE Aero Design<sup>®</sup>

## ADVANCED FLIGHT OPS SUMMARY

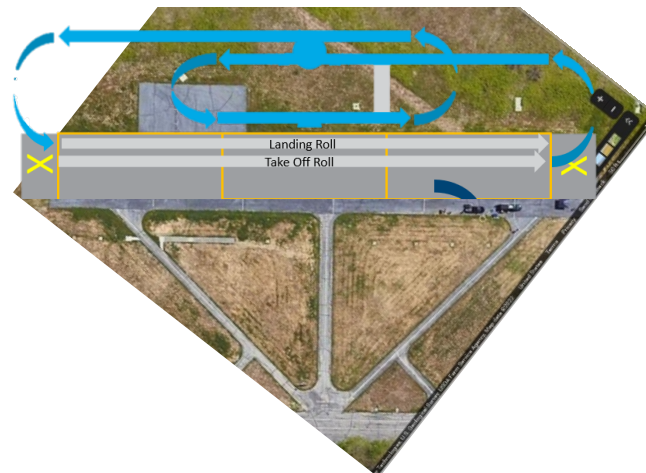

- 3-Team Members at Flight-Line.
- Take-Off Time: 180s
- Land in same direction as take-off on Pavement.
- Declare Payload Release Approach Direction.
- CDA Release >200 ft from Landing Zone

# SAE Aero Design<sup>®</sup>

---

## POST-FLIGHT OPS SUMMARY

- Wait for your flight steward to meet you at the aircraft.
- Unplug your arming plugs as soon as possible for all classes!
- Report to weigh-in station if flight is successful.
- Do not disassemble aircraft until told to do so.

# SAE Aero Design<sup>®</sup>

---

## Other topics:

- Lunches will be provided to Students on Saturday and Sunday
  - Redeem lunch ticket (distributed during check in)
  - Vegetarian options are available
- Water bottles are available. Please stay hydrated.
- Sunscreen is available. Please use sunscreen to avoid sunburn.
- EMT medical team onsite all three days
- **No Open-Toed Shoes – This applies to any and all attendees!**
- [Spectator Policy](#)

# SAE Aero Design<sup>®</sup>

---

## Things to Eat in Los Angeles (From Ed)

- In N Out
- Fat Sal's
- Sawtelle Area (Little Tokyo)
- Any and all Tacos
  - Ed loves Blue Plate Taco, Benny's Tacos, Sonoritas Prime Tacos, Tacos Por Favore
- Pizza
  - Prince Street
  - Pizzana
  - Jon & Vinnys
- Din Tai Fung
-

# SAE Aero Design®

---

## Things to Do in Los Angeles

- Warner Brothers Studio Tour
- Paramount Studios Tour
- Universal Studio Tour
  - Ride inside Universal Studios Park
- Sony Studio Tour
- Hike/Walk Runyon Canyon
- Santa Monica Pier
- Malibu Pier
- Manhattan Beach
- Venice Beach & Boardwalk
- Century City Mall
  - Eataly
  - Din Tai Fung

Collegiate Design Series

# SAE Aero Design<sup>®</sup>

---

**THANK YOU FOR COMPETING THIS  
YEAR!**

